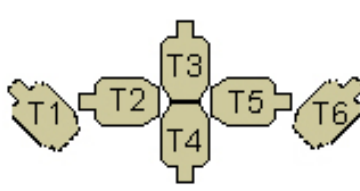

Stage #1 - Standards

Bay Sponsor - NRA Stage Sponsor - Nick's Gun and Pawn Stage Sponsor - Berry's Manufacturing	Course Designer: Mark Goede Safety Officers - CSO Steve Stricklin, SO Laszlo Szabo, and SO Brad Schilling
Scenario: Standards	Scoring: Limited Vickers Count RD Count: 18 only Targets: 6 IDPA Target Distance: 6 - 25 yds Scored Hits: Best 3 on paper Start-Stop: Audible - Last Shot Cover Garment: Not Required
<p>String 1 - Gun holstered and loaded to division capacity. At P1 facing up-range with hands in the surrender position, with hands elevated above shoulders. At signal, turn then draw and fire 1 shot each at T1 - T6 in any order, then do a reload with retention and fire 1 more shot each at T1 - T6 in any order, for a total of 12 rounds. (Normal reload for revolvers).</p> <p>String 2 - Gun in weak hand, loaded to division capacity, at the low ready position, (pointing at orange cone, with finger out of the trigger guard), safety may be off. At signal, fire 1 shot each at T1 - T6 in any order with weak hand only.</p>	
 <p style="margin-top: 20px;">6 yards P2</p> <p style="margin-top: 40px;">25 Yards P1</p>	

Stage #2 - Snowman Left Behind

Bay Sponsor - **Electronic Shooters Protection**
 Stage Sponsor - **Mike Gibson Manufacturing**
 Stage Sponsor - **Wolf Gunsprings**

Course Designer: Will Steffen
Safety Officers - CSO Jeff Meyers, SO Gary Hern and SO Mike Bellafiore

Scenario: It's too cold to hit the range so you sit down for an afternoon of watching IDPA matches on YouTube. You hear screaming from the front of your house. The kids you hired to shovel your drive are being attacked by gang members. Some of the bad guys are using snow shovels as hard cover. Shoot the hard cover and they will drop the shovel, or just shoot around it.

Start Position: P1, Gun loaded to division capacity on table by the window. All ammunition on belt. Seated with back against chair, fingers on the keyboard, feet under desk in normal position.
Consider: They are shooting back, so take cover, even at the windows.

Scoring: Vickers Count
RD Count: 12 Minimum
Targets: 6 IDPA and 2 NT's
Target Distance: 7 - 13 yds
Scored Hits: Best 2 on paper
Start-Stop: Audible - Last Shot
Cover Garment: Not Required

Stage Procedure: At signal, retrieve gun from table and engage T1-T2. Proceed to P2 and open door and engage T3-T4. Proceed to P3 and engage T5-T6. STEEL DOES NOT NEED TO BE HIT THEREFORE DOES NOT NEED TO FALL. Watch your muzzle while opening the door. Slice the pie at EVERY position.

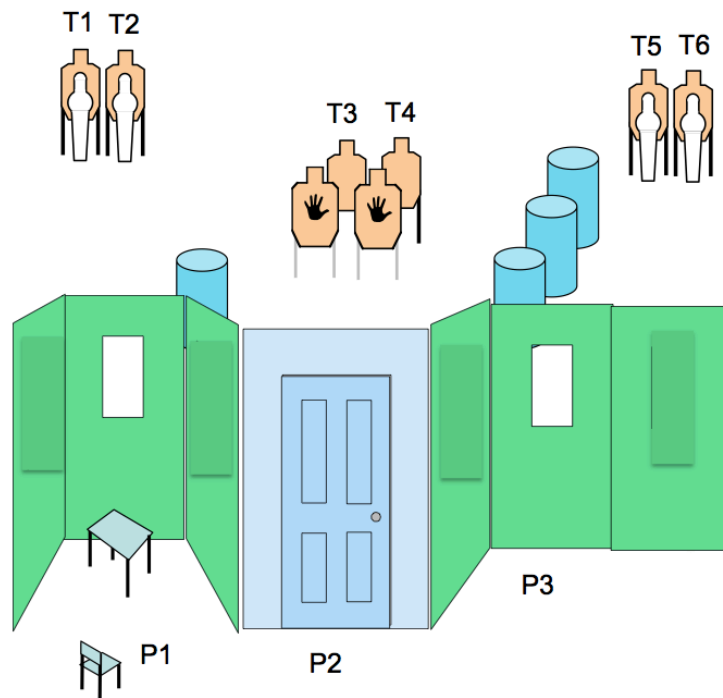

Stage #3 - John McClain

Bay Sponsor - **Adventure Shooting Sports**
 Stage Sponsor - **MO-CSA**
 Stage Sponsor - **Starline Brass**

Course Designer: Steve Filla & Will Steffen
Safety Officers - CSO Ken Rihanek, CSO Steve Filla and SO Tim Barker

Scenario: You are an off duty New York police officer. While picking up your wife at the airport you realize that a team of turncoat commandos are taking over the airport. The man on the conveyor belt has the detonator, stop him from blowing up your wife's plane.

Start Position: P1, facing down range, a piece of luggage in each hand, gun loaded to division capacity.
Consider:

Scoring: Vickers Count
RD Count: 16 Minimum
Targets: 8 IDPA and 2 NT's
Target Distance: 5 - 15 yds
Scored Hits: Best 2 on paper
Start-Stop: Audible - Last Shot
Cover Garment: Required

Stage Procedure: At signal, take cover using the baggage cart. There is just enough space between the baggage in the cart that you can shoot through. Engage T1-T2 through the luggage cart, T3-T4 from P2, T5-T6 from P3, remaining targets from window at P4.

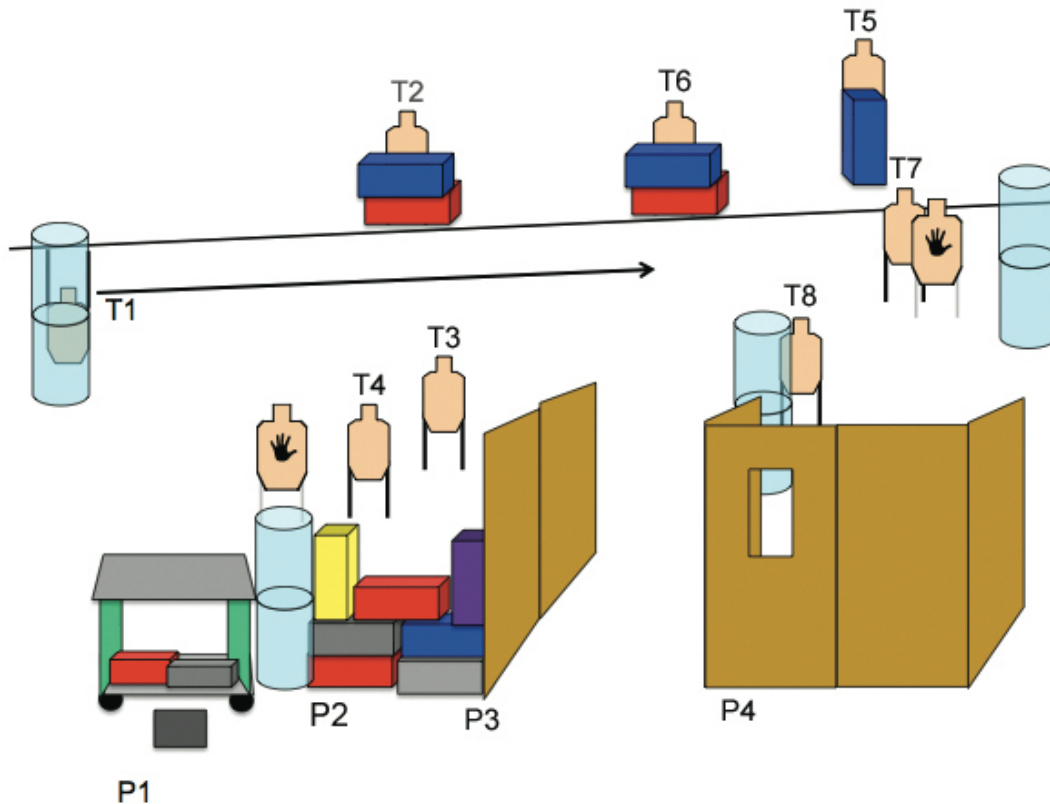

Stage #4 - Call 911!

Bay Sponsor - **Gargoyles Eyewear**
 Stage Sponsor - **XS Sight System**
 Stage Sponsor - **STI**

Course Designer: Mark Goede
Safety Officers - CSO Brian Hajec, SO John Stein and SO Bill Corley

Scenario: You are in downtown St. Louis on the landing when all heck breaks loose. Luckily you are near a public phone and start to call 911, but before you can talk to the police, the bad guys start firing on you.

Start Position: P1, Weak hand holding the phone handset and strong hand on rotary dial. Gun holstered and loaded to division capacity.

Consider: You must start to dial 911 to start the movers, once the movers start, defend yourself.

Scoring: Vickers Count

RD Count: 17 Minimum

Targets: 8 IDPA, 1 PP and 3 NT's

Target Distance: 4 - 15 yds

Scored Hits: Best 2 on paper

Start-Stop: Audible - Last Shot

Cover Garment: Required

Stage Procedure: At signal, began to dial "911" on the phone. Once the movers start moving, engage T1 - T3 in any order, either on the move to P2 or standing still. Move to P2, P3 and P4 and engage T4 - T8 and PP1 when visible in Tactical Priority (slice the pie). T7 may be engaged prior to T6 if you are fast enough.

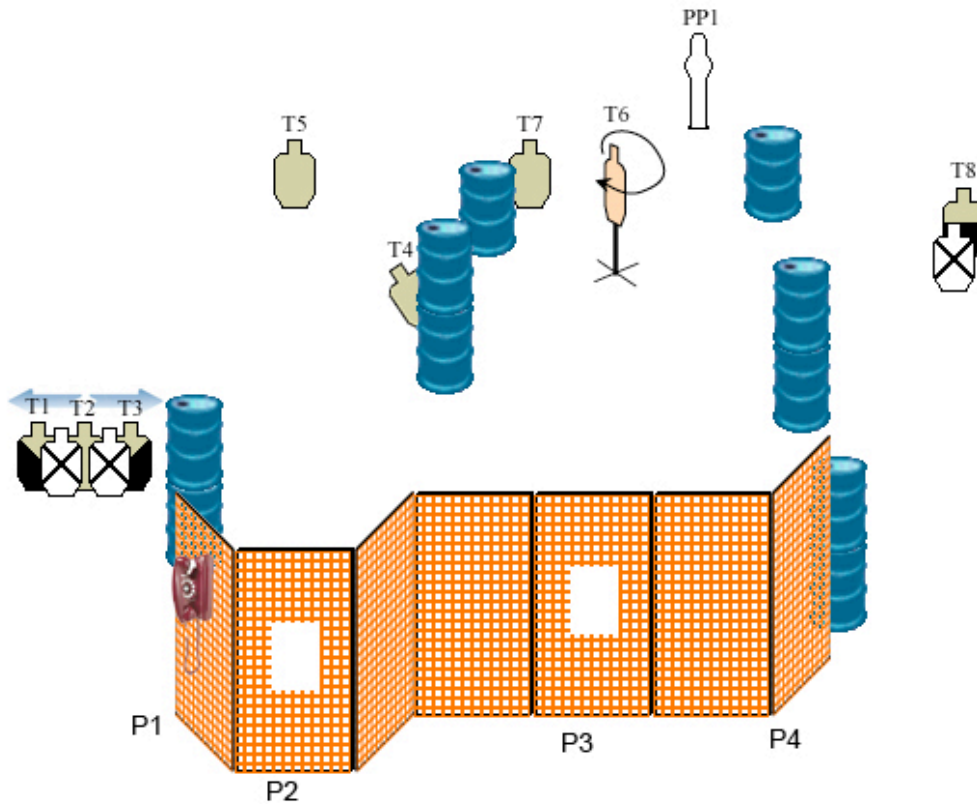

Stage #5 - Who let the dogs out?

Bay Sponsor - **AP Custom**
 Stage Sponsor - **Crimson Trace**
 Stage Sponsor - **Hogue Grips**

Course Designer: George Shoji
Safety Officers - CSO George Shoji, CSO John Koch and SO Don Freeze

Scenario: You are in your bedroom when your spouse goes to investigate why the dogs are barking in the back yard. You then hear glass breaking and the sound of gunfire.

Start Position: P1, sitting in your chair facing up range, reading a book, both hands holding the book. Gun loaded to division capacity with all extra mags or speedloaders sitting on the end table.
Consider: Watch your muzzle as you move from window to window.

Scoring: Vickers Count
RD Count: 18 Minimum
Targets: 7 IDPA, 2 PP and 3 NT's
Target Distance: 5 - 15 yds
Scored Hits: Best 2 on paper
Start-Stop: Audible - Last Shot
Cover Garment: Not Required

Stage Procedure: At signal, retrieve your gun and spare ammo, stow your spare ammo on your person in accordance with IDPA rules. Engage targets as they become visible. All targets get 2 rounds each and engage in Tactical Priority (slice the pie). Be aware of two targets that slip by you and make it into the house when you don't expect. (two additional targets will appear after last pepper popper falls)

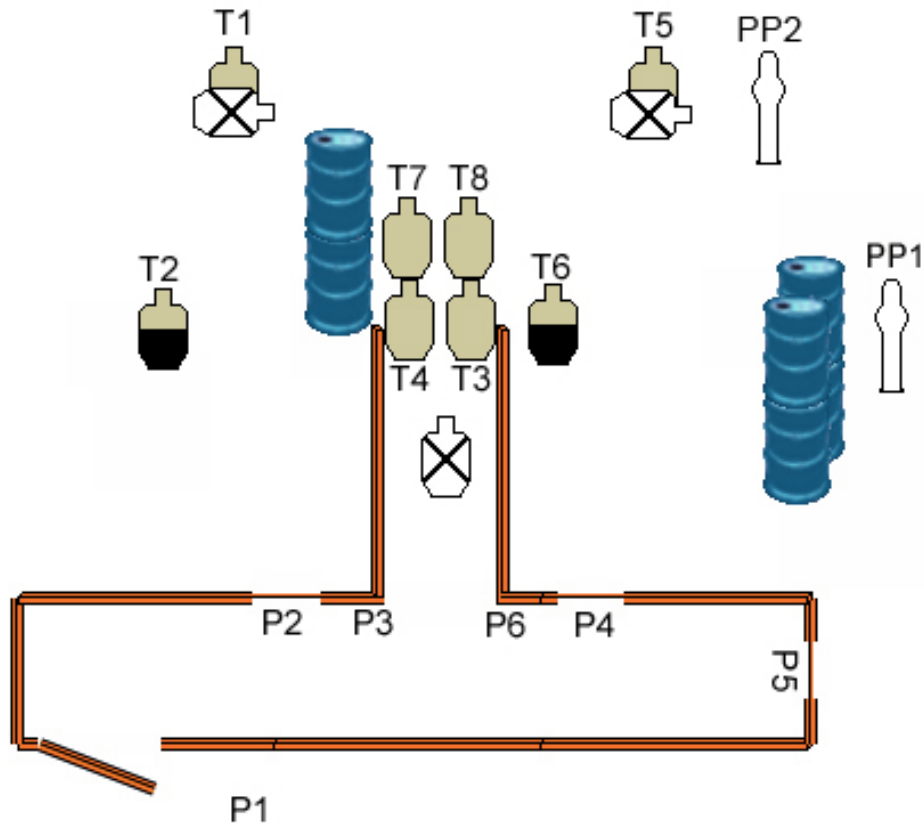

Stage #6 - ATM Robbery

Bay Sponsor - **Top Gun Shooting Range**
Stage Sponsor - **Glock Triggers**
Stage Sponsor - **CompTac**

Course Designer: Mark Goede
Safety Officers - CSO Mark Konya, SO Keith Connelly and SO Mike Mates

Scenario: You just stopped by your bank's ATM and while retrieving your money from the machine you hear a loud voice say "Give me your money or you're dead!" As you protect yourself from the first perpetrator, his buddies start firing and shatter your windshield.

Start Position: P1, gun loaded to division capacity on passenger seat pointing downrange, extra mags on your belt. Left hand at 12 o'clock position on steering wheel, and right elbow on arm rest.
Consider: Watch your muzzle.

Scoring: Vickers Count
RD Count: 12 Minimum
Targets: 6 IDPA, and 2 NT
Target Distance: 3 - 15 yds
Scored Hits: Best 2 on paper
Start-Stop: Audible - Last Shot
Cover Garment: Not Required

Stage Procedure: At signal, retrieve your gun and engage T1 through the passenger window, then engage T2 through T6 through the windshield in tactical priority (near to far). All targets get 2 rounds each.

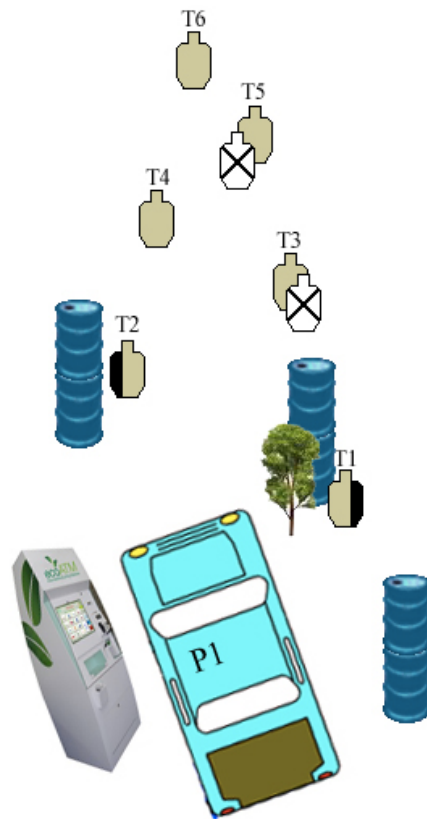

Stage #7 - Get out of bed!

Bay Sponsor - **Top Gun Shooting Range**
 Stage Sponsor - **Dillion Precision**
 Stage Sponsor - **Hi-Viz Sights**

Course Designer: Mark Goede
Safety Officers - CSO Vince Winkeler, SO Ken DeGrant and SO Charles Thompson

Scenario: You are asleep in bed when your spouse interrupts 4 bad guys breaking and entering. You see three right away, but the fourth took cover and is hiding in the hallway.

Start Position: P1, laying parallel on the bed, back of knees touching the bed, hands folded across chest. Gun is loaded to division capacity in the top drawer of the night stand. Place your extra mags or speedloaders in the drawer with your gun.
Consider: Watch your muzzle as you remove your gun from the night stand.

Scoring: Vickers Count
RD Count: 12 Minimum
Targets: 4 IDPA, 1 NT
Target Distance: 4 - 8 yds
Scored Hits: Best 3 on paper
Start-Stop: Audible - Last Shot
Cover Garment: Not Required

Stage Procedure: At signal, get out of and use your bed as cover while you retrieve your gun and spare mags or speedloaders from the night stand. Engage targets as they are visible in tactical priority (near to far) with 3 rounds each. Engage T1-T3 from P1. T1 and T2 are equal threats and may be engaged in any order. Move to P2 and engage T4 from foot of bed either prone or from a knee. All threats get 3 (three) rounds each. You may reload with retention from P1. You can't stow you mags in your mag pouches, inside waistband or pockets are fine.

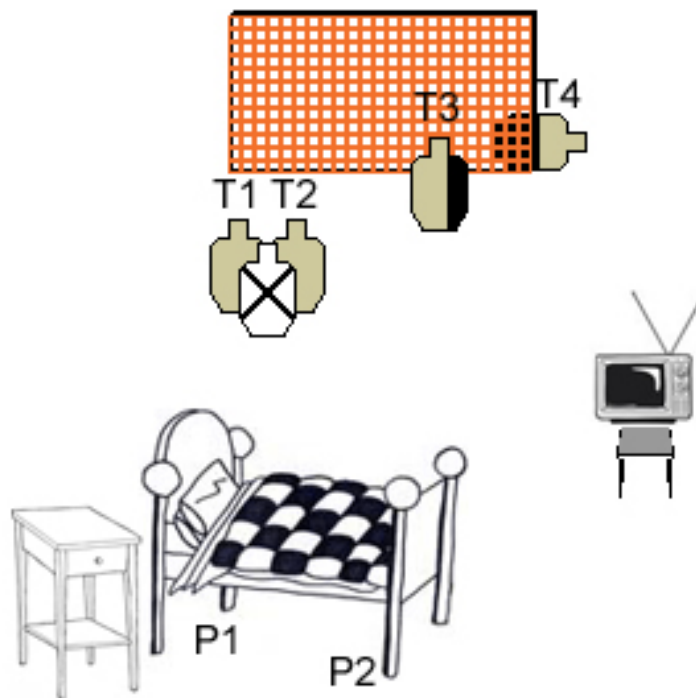

Stage #8 - Meth Lab Showdown

Bay Sponsor - **Cheaper Than Dirt**
 Stage Sponsor - **Brownells**
 Stage Sponsor - **Glock**

Course Designer: Jeff Duckworth
Safety Officers - CSO Jeff Duckworth, SO Adam Proctor and SO Thad Mueller

Scenario: You are a Reserve Police Officer for a county full of meth labs. The meth heads have declared war against the police and vow not to be taken alive.

Start Position: P1, gun holstered and loaded to division capacity. Hands naturally at your side.
Consider: Don't sweep your hand when opening the door.
 Moving targets are electric on this stage.

Scoring: Vickers Count
RD Count: 16 Minimum
Targets: 8 IDPA, 1 NT
Target Distance: 4 - 15 yds
Scored Hits: Best 2 on paper
Start-Stop: Audible - Last Shot
Cover Garment: Required

Stage Procedure: At signal, take cover and engage T1 - T3 in tactical priority (slice the pie), move to P2 and first engage targets through windows as they become visible, then open door and engage remaining target. All targets get two rounds minimum.

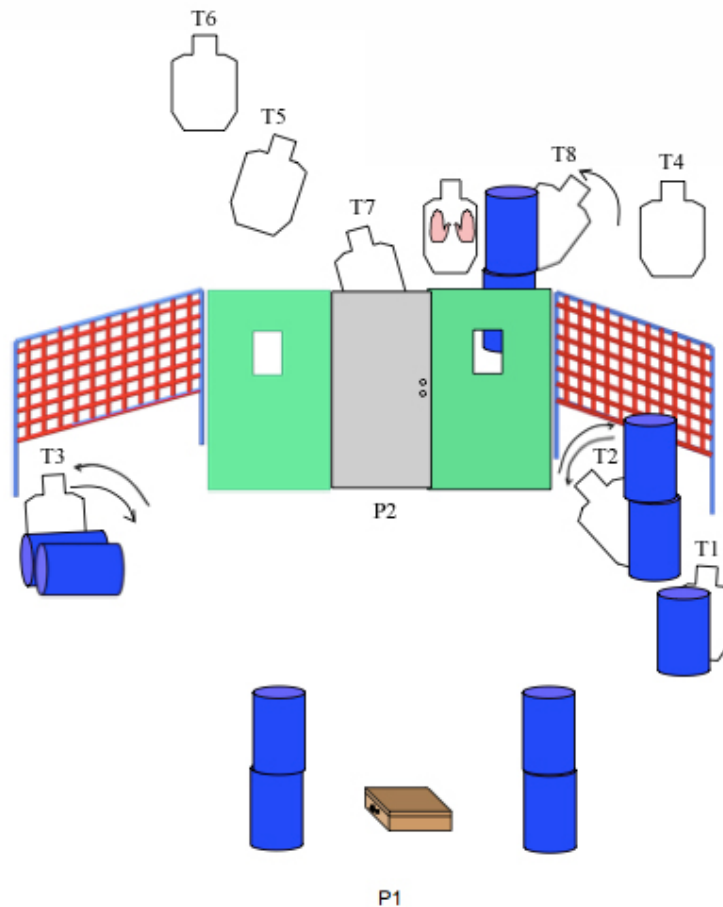

Stage #8 - Bullseye Bay

Stage #9 - Get Geronimo

Match Sponsor - **Metro Shooting Supplies**
 Bay Sponsor - **TDSA**
 Stage Sponsor - **Safariland**

Course Designer: Jere Wilmering
Safety Officers - CSO Rod Aman, SO Marc Gottfried and SO Don Gaikins

Scenario: You are part of a special task force seeking a high value target in a foreign land. Months of intelligence says **GERONIMO** is in this structure and poses a lethal threat. He is disguised but his identity will be revealed to you by an informant during the operation. Take him out -- along with his armed guards.

Start Position: At P1, gun holstered, loaded to division capacity, holding your rifle up to shoulder with cheek on stock, rifle aiming at designated point down range. Rifle is attached to you with a sling.
Consider: The identity of Geronimo will be known to you when you see his “**Insignia**” at the window to his living quarters. Only ONE target will be so marked, all others are Non-Threats.

Scoring: Vickers Count
RD Count: 17 Minimum
Targets: 14 IDPA, 3 NT
Target Distance: 3 - 10 yds
Scored Hits: Best 1 on paper, 3 on Geronimo
Start-Stop: Audible - Last Shot
Cover Garment: Not Required

Stage Procedure: At buzzer lower rifle and draw pistol, enter the hallway, clear rooms from P2 to P6 (slicing the pie) as you make your way towards the living quarters for Geronimo. Engage all targets with at least 1 round. You must make proper use of cover at every doorway. Once at the living quarters be sure you only engage the designated Geronimo (T15) and do so with **two rounds to the body and one to the head** in case he is wearing armor. (you may reload between P5-P6)

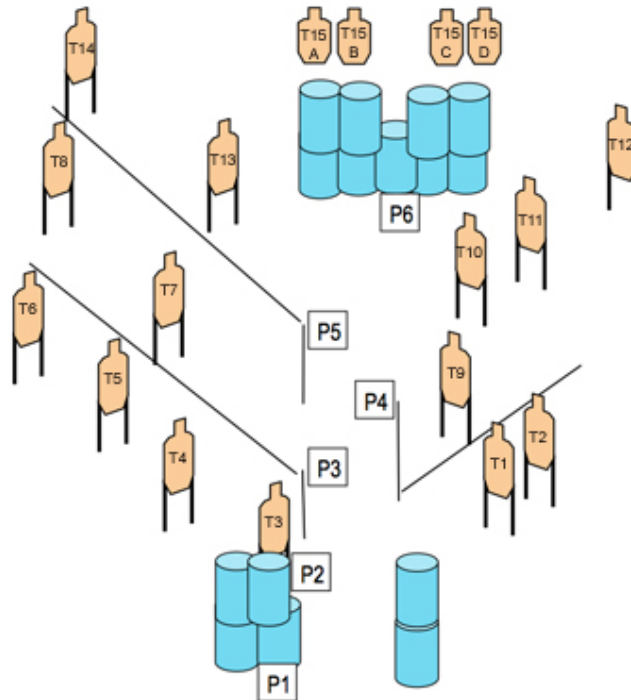

Stage #9 - Combat Bay

Stage #10 - Man Down!

Bay Sponsor - **TDSA**
 Stage Sponsor - **Maryland Yards**
 Stage Sponsor - **Blade-Tech Industries**

Course Designer: Mark Goede
 Safety Officers - CSO Dave Birk, SO Ty
 Welchlen and SO Michael Young

Scenario: You are caught behind enemy lines and your commanding officer is down. He has saved your hide more than once, now is the time to repay that debt. You must drag him with you to safety.

Start Position: P1, gun holstered and loaded to division capacity, weak hand used to drag the commander to safety. Strong hand holding the hand held radio to your head.
Consider: The Commander has to be completely behind cover or a procedural will be earned. If a threat can see any part of the commander, then he is not behind cover.

Scoring: Vickers Count
RD Count: 12 Minimum
Targets: 6 IDPA
Target Distance: 8 - 9 yds
Scored Hits: Best 2 on paper
Start-Stop: Audible - Last Shot
Cover Garment: Required
Note: P1 to cover is 4 yards

Stage Procedure: At signal, drag the commander with weak hand to safety while engaging targets with strong hand only on the move to cover (six shots must be shot on the move). When the commander is completely and safely behind cover, engage remaining targets in tactical priority (slice the pie). You may re-engage all targets freestyle once you and the commander are both safely behind cover. You may use two hands to reload or clear a jam.

